

2020nm FP LASER

EP2020-FP-B



eblanaphotonics



SUPERIOR PERFORMANCE

Eblana Photonics EP2020-FP-B laser diode, available in range from 1950-2150nm, is a cost effective, highly coherent laser source. Eblana's advanced epistructure design is used to deliver an InP-based strained quantum-well FP laser with applications in CO₂ monitoring and free space comms.

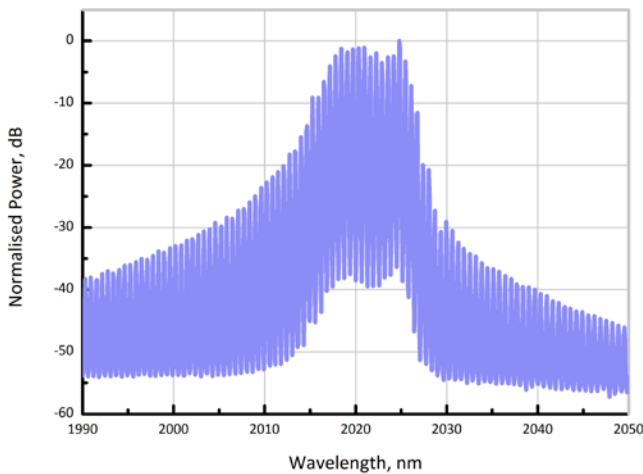

Optical Spectrum at 25°C

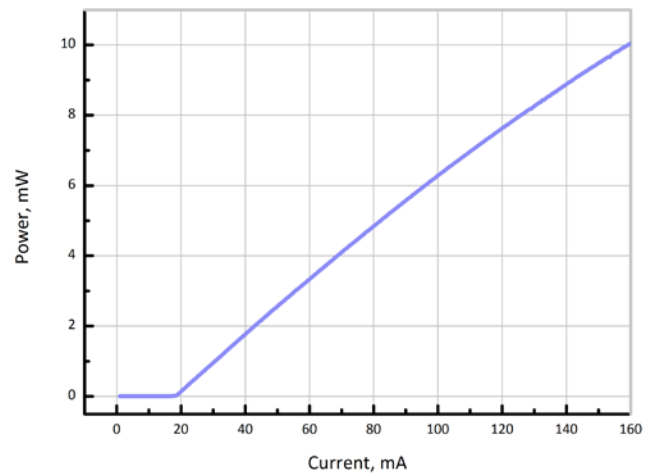

Representative wavelength-current tuning characteristics

ELECTRO-OPTICAL CHARACTERISTICS* (T_{SUB} = 25° C)

PARAMETER	SYMBOL	MIN	TYP	MAX	UNIT
Centre Wavelength Range	λ	1950	2020	2150	nm
Side Mode Supression Ratio	SMSR	30	40		dB
Threshold Current	I _{th}	-	20	30	mA
Output Power in fiber	P _f	6	10	14	mW
Temperature Tuning Coefficient	T _{λ}	-	0.1	-	nm/°C
Current Tuning Coefficient	I _{λ}	-	0.01	-	nm/mA
Slope Efficiency	SE	0.05	0.08	-	mW/mA
Forward Voltage	V _f	-	1.3	1.6	V
Thermistor Resistance	R _T	9.5	10	10.5	k Ω
Thermistor Temp. Coefficient	C	-	-4.4	-	%/°C

*CW bias unless otherwise stated

©Eblana Photonics Series 2020-FP-B Rev 2.0

ABSOLUTE MAXIMUM RATINGS

PARAMETER	SYMBOL	MIN	TYP	MAX	UNIT
Forward Current	I_f	-	-	220	mA
TEC Current	I_{TEC}	-	-	1.2	A
Reverse Voltage LD	V_{rev}	-	-	2.0	V
Case Temperature*	T_{Case}	-20	-	50	°C
Chip Submount Temperature	T_{Sub}	0	--	50	°C
Storage Temperature	$T_{storage}$	-40	-	85	°C

*For $T_{sub} < 25^{\circ}C$, Max Case Temperature should be derated to $T_{Case,Max} = T_{sub} + 40^{\circ}C$

PACKAGING

The EP2020-FP-B product series is offered in a 14-pin Butterfly package - Inquire for alternative packaging options. The standard package pinout is shown below, variations may be requested. mPD not included as standard.

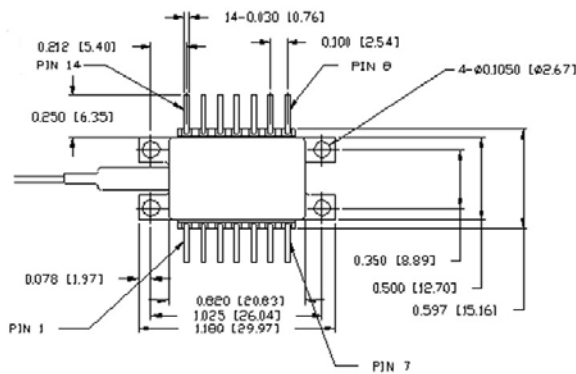

14-pin butterfly schematic

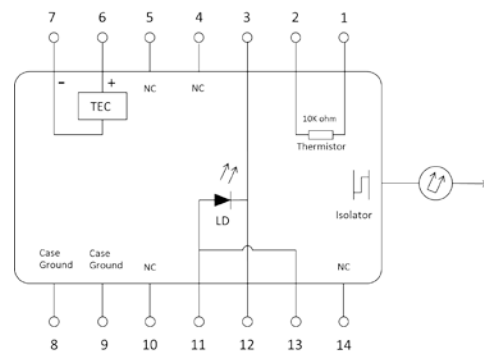

Standard "Pinout 06" option

HOW TO ORDER

Construct your part number using the following example and email your order to contact@cybel-llc.com

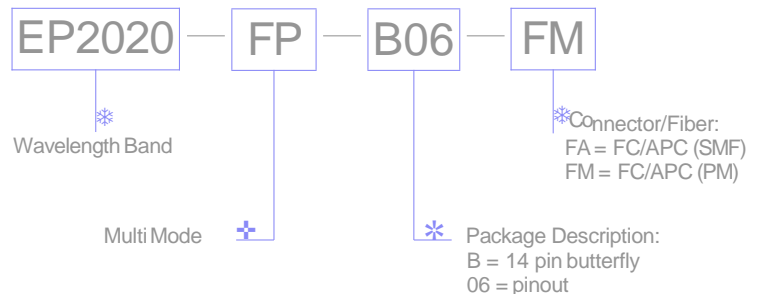

Laser Safety

This is a Class 3R Laser Product as defined by International Standard IEC 60825-1, Edition 2. Invisible Laser radiation is emitted from the end of the fiber or connector. Avoid direct eye exposure to the beam. Laser safety labels are not attached to the module due to space limitations but instead are affixed to the outside of the shipping carton.

©Eblana Photonics 2013. Eblana Photonics Reserves the right to amend this document at any time, without prior warning. ©Eblana Photonics Series 2020-FP-B Rev 2.0