

The DR-DG-20-MO is a high performance versatile driver module designed for 2.5 Gbps up to 20 Gbps data transmission with NRZ or RZ format. It exhibits a 28 dB gain and can deliver an output signal up to $9 V_{pp}$.

The DR-DG-20-MO is a key component to obtain high quality 2.5 Gbps up to 20 Gbps eye diagrams with low rise and fall time, low jitter and high SNR. It operates from a single power supply for safety and ease of use, and offers gain and cross point controls. It comes with K type RF connectors (female in, male out) and with an optional heat-sink.

FEATURES

- Output voltage up to $8 V_{pp}$
- Low Rise/Fall time
- Flat gain up to 20 GHz
- Single voltage power supply
- Low group delay variation

APPLICATIONS

- LiNbO₃ modulators
- 20 Gbps NRZ and RZ
- Research & Development

OPTIONS

- Heat-sink

Performance Highlights

Parameter	Min	Typ	Max	Unit
Cut-off frequencies	50 k	-	18 G	Hz
Output voltage	2	-	8	V_{pp}
Gain	28	30	-	dB
Saturated output power	-	-	23	dBm
Added jitter	-	0.9	-	ps
Rise / Fall times	-	14	-	ps

Measurements for $V_{bias} = 12 V$, $V_{amp} = 0.65 V$, $V_{xp} = 1 V$, $I_{bias} = 319 mA$

20 Gbps Output Response

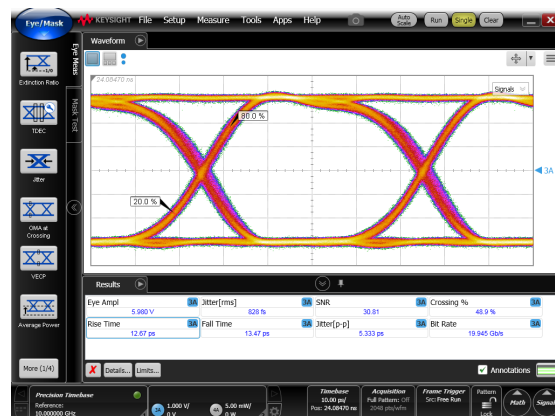

DC Electrical Characteristics

Parameter	Symbol	Min	Typ	Max	Unit
Supply voltage (fixed)	V_{bias}	-	12	-	V
Current consumption	I_{bias}	-	260	-	mA
Gain control voltage	V_{amp}	-	0.5	-	V
Cross Point control voltage	V_{xp}	-	0.9	-	V

Electrical Characteristics

Parameter	Symbol	Condition	Min	Typ	Max	Unit
Lower frequency	f_{3dB}^{lower}	-3 dB point	-	-	50	kHz
Upper frequency	f_{3dB}^{upper}	-3 dB point	18	20	-	GHz
Gain	S_{21}	Small signal	28	30	-	dB
Gain ripple	-	$f < 15$ GHz	-	± 1.5	-	dB
Input return loss	S_{11}	10 MHz $< f < 12$ GHz	-	-10	-	dB
Output return loss	S_{22}	10 MHz $< f < 15$ GHz	-	-10	-	dB
Saturated output power	P_{sat}	$V_{in} = 0.5 V_{pp}$	22	23	-	dBm
Output voltage	V_{out}	$V_{in} = 0.5 V_{pp}$	2	-	8	V_{pp}
Rise / Fall time	t_r / t_f	20 % - 80 %	-	12 / 16	-	ps
Added jitter	J_{RMS}	$J_{RMS} = \sqrt{J_{RMS-total}^2 - J_{RMS-source}^2}$	-	0.9	-	ps
Noise Figure	NF	1 GHz $< f < 20$ GHz	3.5	-	6	dB
Power dissipation	P	$V_{out} = 8 V_{pp}$	-	3.2	-	W

Conditions: $V_{in} = 0.5 V_{pp}$, $T_{amb} = 25$ °C, 50 Ω system

Absolute Maximum Ratings

Stresses in excess of the absolute maximum ratings can cause permanent damage to the device. These are absolute stress ratings only. Functional operation of the device is not implied at these or any other conditions in excess of those given in the operational sections of the data sheet. Exposure to absolute maximum ratings for extended periods can adversely affect device reliability.

Parameter	Symbol	Min	Max	Unit
RF input voltage	V_{in}	-	1	V_{pp}
Supply voltage	V_{bias}	11	13	V
DC current	I_{bias}	0	0.4	A
Gain control voltage	V_{amp}	0	1.2	V
Cross Point control voltage	V_{xp}	0	1.1	V_{pp}
Power dissipation	P_{diss}	-	5.2	W
Temperature of operation	T_{op}	0	+40	°C
Storage temperature	T_{st}	-20	+70	°C

S_{21} and Group Delay Parameter Curves

Conditions: $V_{bias} = 12\text{ V}$, $V_{amp} = 0.65\text{ V}$, $V_{xp} = 1\text{ V}$, $I_{bias} = 319\text{ mA}$

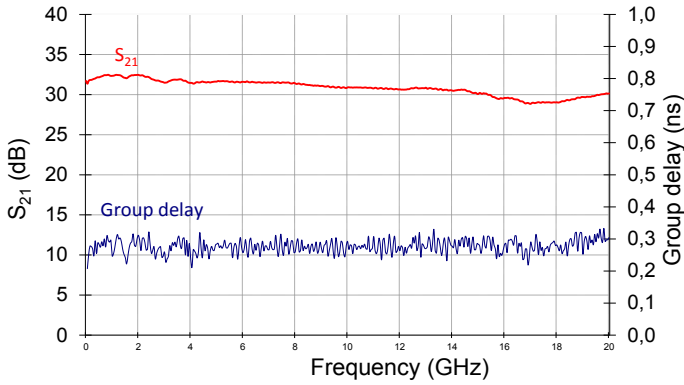

S_{12} Parameter Curve

Conditions: $V_{bias} = 12\text{ V}$, $V_{amp} = 0.65\text{ V}$, $V_{xp} = 1\text{ V}$, $I_{bias} = 319\text{ mA}$

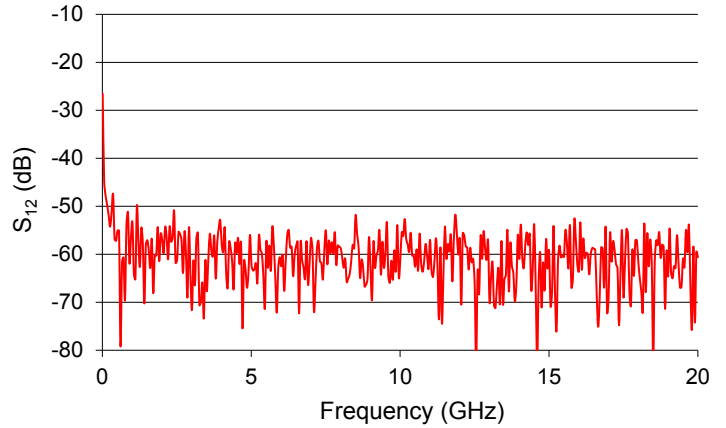

S_{22} Parameter Curve

Conditions: $V_{bias} = 12\text{ V}$, $V_{amp} = 0.65\text{ V}$, $V_{xp} = 1\text{ V}$, $I_{bias} = 319\text{ mA}$

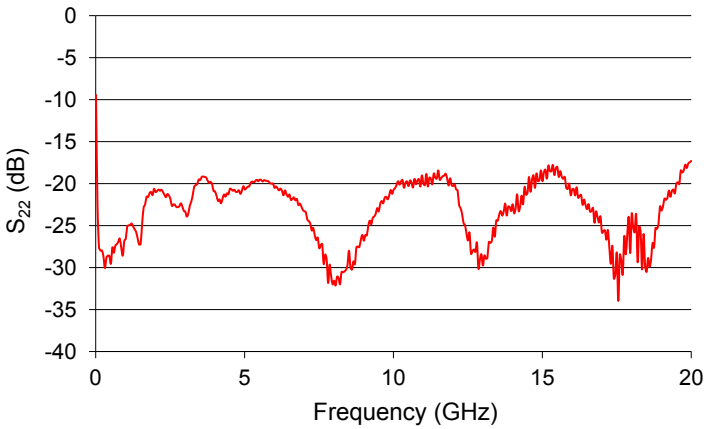

S_{11} Parameter Curve

Conditions: $V_{bias} = 12\text{ V}$, $V_{amp} = 0.65\text{ V}$, $V_{xp} = 1\text{ V}$, $I_{bias} = 319\text{ mA}$

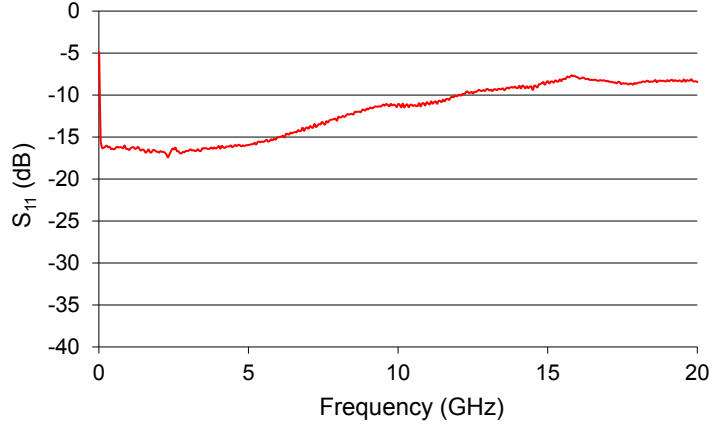

Typical Output Voltage Amplitude vs V_{amp}

Conditions: $V_{bias} = 12\text{ V}$, $V_{in} = 0.5\text{ V}$

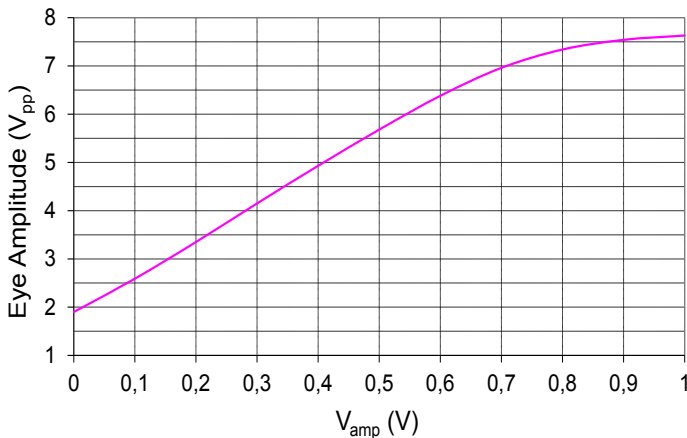

Typical Cross point vs V_{xp}

Conditions: $V_{bias} = 12\text{ V}$, $V_{in} = 0.5\text{ V}$

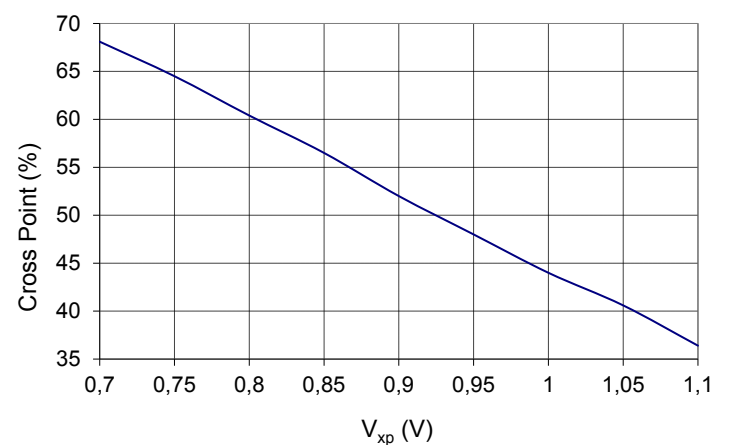

Eye Diagrams

12.5 Gbps data rate

Conditions: Ratio 1/2, Pattern 2³¹-1

$$V_{bias} = 12\text{ V}, V_{amp} = 0.75\text{ V}, V_{xp} = 0.88\text{ V}, I_{bias} = 277\text{ mA}$$

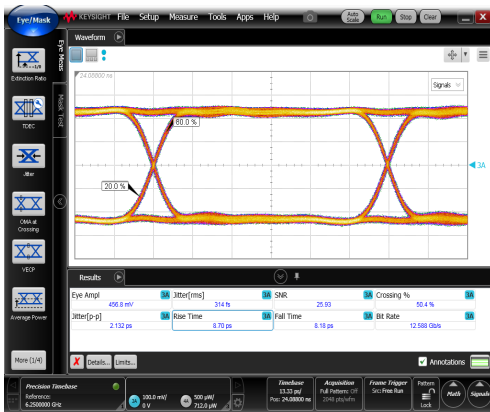

Input signal
Eye amplitude = 0.45 V_{pp}

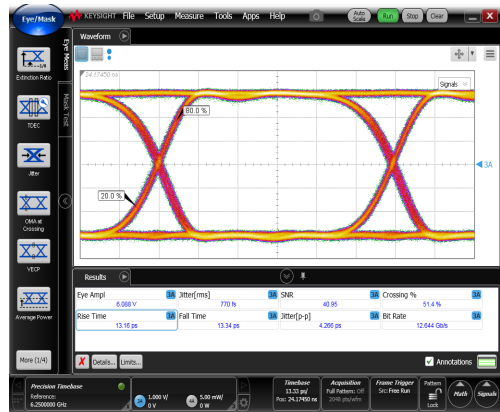

Output response
Eye amplitude = 6 V_{pp}

20 Gbps data rate

Conditions: Ratio 1/2, Pattern 2³¹-1

$$V_{bias} = 12\text{ V}, V_{amp} = 0.65\text{ V}, V_{xp} = 1\text{ V}, I_{bias} = 319\text{ mA}$$

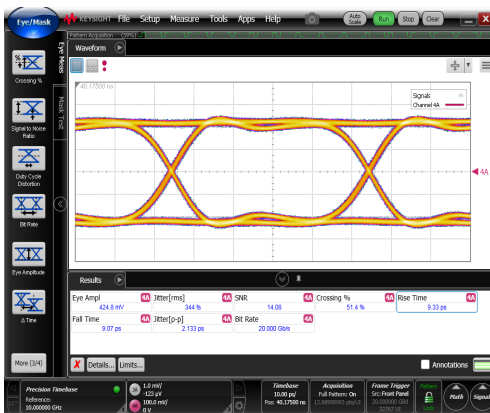

Input signal
Eye amplitude = 0.43 V_{pp}

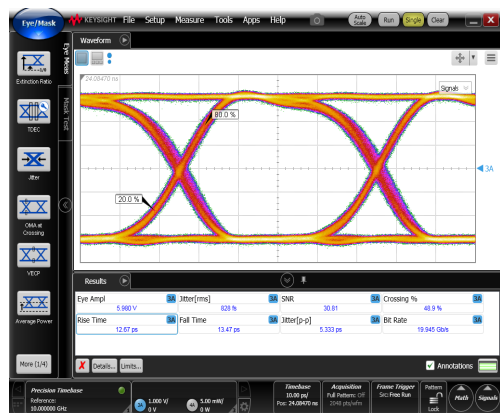

Output response
Eye amplitude = 6 V_{pp}

Electrical Schematic Diagram

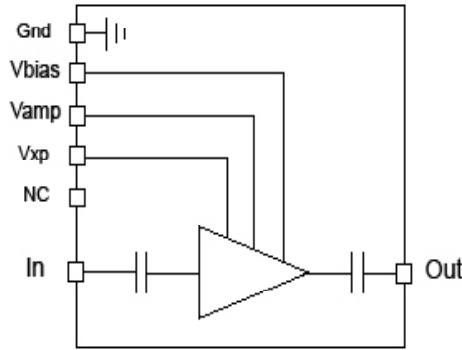

Mechanical Diagram and Pinout

All measurements in mm

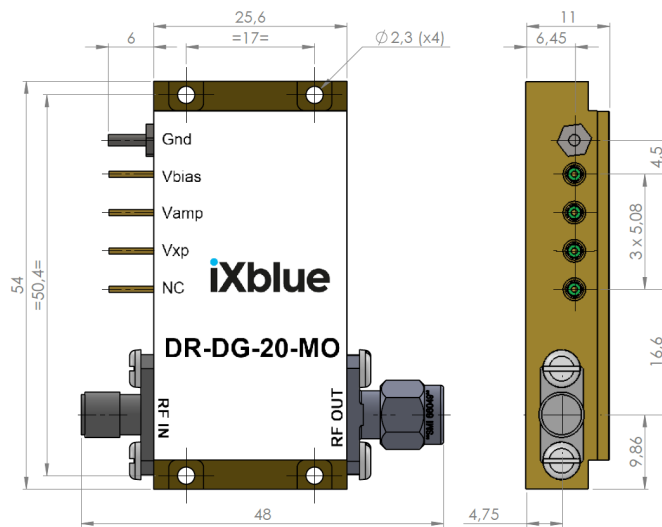

The heat-sinking of the module is necessary. It's user responsibility to use an adequate heat-sink. Refer to page 6 for ixblue recommended heat-sink.

PIN	Function	Operational Notes
IN	RF In	K-connector female
OUT	RF Out	K-connector male
V_{bias}	Power supply voltage	Set at typical operating specification
V_{amp}	Output voltage amplitude adjustment	Adjust for gain control tuning
V_{xp}	Output voltage cross point adjustment	Adjust for cross point control tuning

Mechanical Diagram And Pinout With HS-MO2 Heat-sink

All measurements in mm

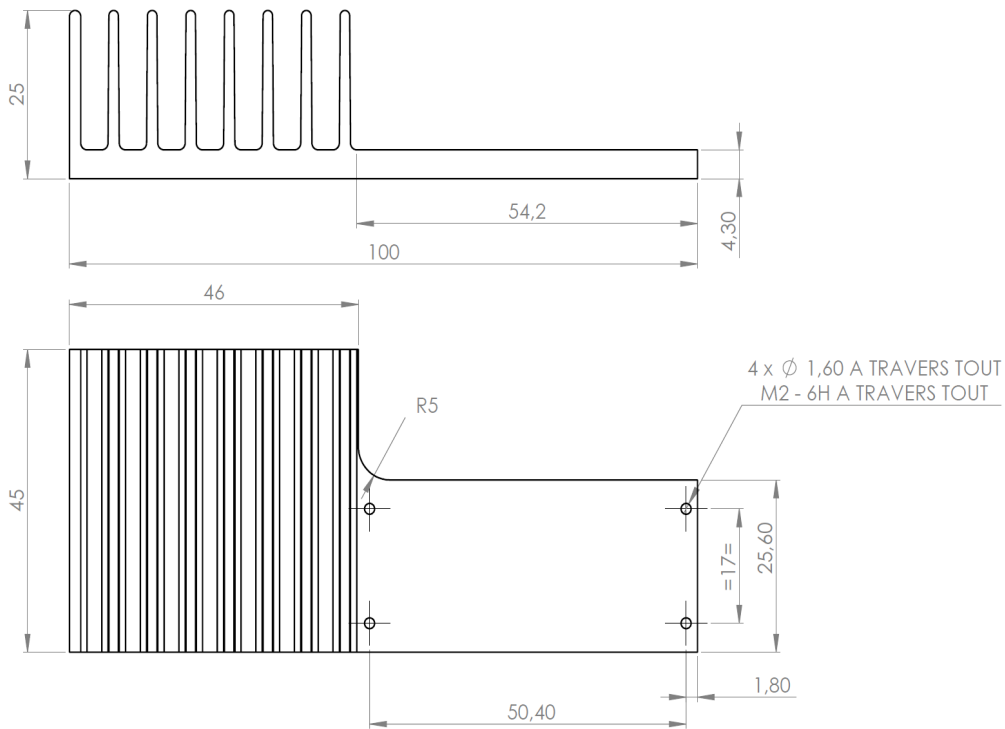
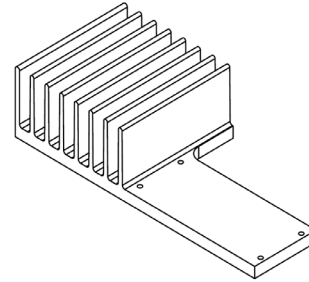

About us

ixblue Photonics produces specialty optical fibers and Bragg gratings based fiber optics components and provides optical modulation solutions based on the company lithium niobate (LiNbO₃) modulators and RF electronic modules.

ixblue Photonics serves a wide range of industries: sensing and instruments, defense, telecommunications, space and fiber lasers as well as research laboratories all over the world.