

## MODULATOR

# NIR-MPX800-LN Series

## 800 nm band Phase Modulators

The Exail NIR-MPX800 series are phase modulators especially designed to operate in the 800 nm wavelength band. They are available with various modulation bandwidth, from low frequency to 20 GHz and beyond.

Like all Exail Near InfraRed (NIR) modulators, the NIR-MPX800 series use a proton exchanged based waveguide process that confers them an unparalleled stability and a high photo-refractive threshold.



### Features

- High optical power handling
- Wide bandwidth (> 18 GHz)
- High stability
- Low  $V_{\pi}$
- Low insertion loss

### Applications

- Interferometric based sensors
- Quantum optics
- Frequency shifting
- Pound-Drever-Hall locking (PDH)

### Options

- 20 GHz version
- 895 nm, 915 nm and 935 nm versions
- Space grade version

### Related Equipments

- RF amplifiers
- NIR-MX800-LN intensity modulators
- 30 ps optical pulse ModBox-PG

### NIR-MPX800-LN-0.1 series Performance Highlights

Parameter	Min	Typ	Max	Unit
Operating wavelength	780	850	890	nm
Usable electro-optical bandwidth	-	300	-	MHz
$V_{\pi}$ RF @50 kHz	-	1	2	V
Insertion loss	-	3.5	4.5	dB

### NIR-MPX800-LN-05 series Performance Highlights

Parameter	Min	Typ	Max	Unit
Operating wavelength	780	850	890	nm
Usable electro-optical bandwidth	-	10	-	GHz
$V_{\pi}$ RF @50 kHz	-	3	4	V
Insertion loss	-	3.5	4.5	dB

### NIR-MPX800-LN-10 series Performance Highlights

Parameter	Min	Typ	Max	Unit
Operating wavelength	780	850	890	nm
Usable electro-optical bandwidth	-	16	-	GHz
$V_{\pi}$ RF @50 kHz	-	4	5	V
Insertion loss	-	3.5	4.5	dB

### NIR-MPX800-LN-20 series Performance Highlights

Parameter	Min	Typ	Max	Unit
Operating wavelength	780	850	890	nm
Usable electro-optical bandwidth	-	20	-	GHz
$V_{\pi}$ RF @50 kHz	-	4	5	V
Insertion loss	-	3.5	4.5	dB

# NIR-MPX800-LN-0.1

## 300 MHz Phase Modulator

### Electrical Characteristics

Parameter	Symbol	Condition	Min	Typ	Max	Unit
Electro-optical bandwidth	$S_{21}$	-	100	150	-	MHz
Usable electro-optical bandwidth	$S_{21}$	-	-	300	-	MHz
$V_{\pi}$ RF @50 kHz	$V_{\pi_{RF50\text{ kHz}}}$	-	-	1	2	V
RF input impedance	$Z_{in-RF}$	-	-	10 000	-	$\Omega$

### Optical Characteristics

Parameter	Symbol	Condition	Min	Typ	Max	Unit
Crystal	-	-	Lithium Niobate X-Cut Y-Prop			
Wavelength	-	-	Proton exchange			
Operating wavelength	$\lambda$	-	780	850	890	nm
Insertion loss	IL	Without optical connectors*	-	3.5	4.5	dB
Optical return loss	ORL	-	-40	-45	-	dB

All specifications given at 25 °C, 850 nm, unless differently specified.

<sup>(1)</sup> Consider an extra-loss up to 0.6 dB for each FC/APC optical connector

### Absolute Maximum Ratings

Stresses in excess of the absolute maximum ratings can cause permanent damage to the device. These are absolute stress ratings only. Functional operation of the device is not implied at these or any other conditions in excess of those given in the operational sections of the data sheet. Exposure to absolute maximum ratings for extended periods can adversely affect device reliability.

Parameter	Symbol	Min	Max	Unit
Modulation voltage range	$EV_{in}$	-20	+20	V
Optical input power (CW mode)	$OP_{in}$	-	+14	dBm
Operating temperature	OT	0	+70	°C
Storage temperature	ST	-40	+85	°C

# NIR-MPX800-LN-05

## 10 GHz Phase Modulator

### Electrical Characteristics

Parameter	Symbol	Condition	Min	Typ	Max	Unit
Electro-optical bandwidth	$S_{21}$	RF electrodes, from 2 GHz	5	-	-	GHz
Usable electro-optical bandwidth	$S_{21}$	RF electrodes, from 2 GHz	-	10	-	GHz
Ripple $S_{21}$	$\Delta S_{21}$	-	-	0.5	1	dB
Electrical return loss	$S_{11}$	-	-	-12	-10	dB
$V_{\pi}$ RF @50 kHz	$V_{\pi_{RF50\text{ kHz}}}$	-	-	3	4	V
RF input impedance	$Z_{in-RF}$	-	-	50	-	$\Omega$

### Optical Characteristics

Parameter	Symbol	Condition	Min	Typ	Max	Unit
Crystal	-	-	Lithium Niobate X-Cut Y-Prop			
Wavelength process	-	-	Proton exchange			
Operating wavelength	$\lambda$	-	780	850	890	nm
Insertion loss	IL	Without optical connectors*	-	3.5	4.5	dB
Optical return loss	ORL	-	-40	-45	-	dB

All specifications given at 25 °C, 850 nm, unless differently specified.

<sup>(1)</sup> Consider an extra-loss up to 0.6 dB for each FC/APC optical connector

### Absolute Maximum Ratings

Stresses in excess of the absolute maximum ratings can cause permanent damage to the device. These are absolute stress ratings only. Functional operation of the device is not implied at these or any other conditions in excess of those given in the operational sections of the data sheet. Exposure to absolute maximum ratings for extended periods can adversely affect device reliability.

Parameter	Symbol	Min	Max	Unit
RF input power (CW mode)	$EP_{in}$	-	+33	dBm
Optical input power (CW mode)	$OP_{in}$	-	+14	dBm
Operating temperature	OT	0	+70	°C
Storage temperature	ST	-40	+85	°C

# NIR-MPX800-LN-10

## 16 GHz Phase Modulator

### Electrical Characteristics

Parameter	Symbol	Condition	Min	Typ	Max	Unit
Electro-optical bandwidth	$S_{21}$	RF electrodes, from 2 GHz	10	12	-	GHz
Usable electro-optical bandwidth	$S_{21}$	RF electrodes, from 2 GHz	-	16	-	GHz
Ripple $S_{21}$	$\Delta S_{21}$	-	-	0.5	1	dB
Electrical return loss	$S_{11}$	-	-	-12	-10	dB
$V_{\pi}$ RF @50 kHz	$V_{\pi_{RF50\text{ kHz}}}$	-	-	4	5	V
RF input impedance	$Z_{in-RF}$	-	-	50	-	$\Omega$

### Optical Characteristics

Parameter	Symbol	Condition	Min	Typ	Max	Unit
Crystal	-	-	Lithium Niobate X-Cut Y-Prop			
Wavelength process	-	-	Proton exchange			
Operating wavelength	$\lambda$	-	780	850	890	nm
Insertion loss	IL	Without optical connectors*	-	3.5	4.5	dB
Optical return loss	ORL	-	-40	-45	-	dB

All specifications given at 25 °C, 850 nm, unless differently specified.

\*<sup>(1)</sup> Consider an extra-loss up to 0.6 dB for each FC/APC optical connector

### Absolute Maximum Ratings

Stresses in excess of the absolute maximum ratings can cause permanent damage to the device. These are absolute stress ratings only. Functional operation of the device is not implied at these or any other conditions in excess of those given in the operational sections of the data sheet. Exposure to absolute maximum ratings for extended periods can adversely affect device reliability.

Parameter	Symbol	Min	Max	Unit
RF input power (CW mode)	$EP_{in}$	-	+33	dBm
Optical input power (CW mode)	$OP_{in}$	-	+14	dBm
Operating temperature	OT	0	+70	°C
Storage temperature	ST	-40	+85	°C

# NIR-MPX800-LN-20

## 20 GHz Phase Modulator

### Electrical Characteristics

Parameter	Symbol	Condition	Min	Typ	Max	Unit
Electro-optical bandwidth	$S_{21}$	RF electrodes, from 2 GHz	16	20	-	GHz
Ripple $S_{21}$	$\Delta S_{21}$	-	-	0.5	1	dB
Electrical return loss	$S_{11}$	-	-	-12	-9	dB
$V_{\pi}$ RF @50 kHz	$V_{\pi_{RF50\text{ kHz}}}$	-	-	4	5	V
RF input impedance	$Z_{in-RF}$	-	-	50	-	$\Omega$

### Optical Characteristics

Parameter	Symbol	Condition	Min	Typ	Max	Unit
Crystal	-	-	Lithium Niobate X-Cut Y-Prop			
Wavelength process	-	-	Proton exchange			
Operating wavelength	$\lambda$	-	780	850	890	nm
Insertion loss	IL	Without optical connectors*	-	3.5	4.5	dB
Optical return loss	ORL	-	-40	-45	-	dB

All specifications given at 25 °C, 850 nm, unless differently specified.

\*<sup>(1)</sup> Consider an extra-loss up to 0.6 dB for each FC/APC optical connector

### Absolute Maximum Ratings

Stresses in excess of the absolute maximum ratings can cause permanent damage to the device. These are absolute stress ratings only. Functional operation of the device is not implied at these or any other conditions in excess of those given in the operational sections of the data sheet. Exposure to absolute maximum ratings for extended periods can adversely affect device reliability.

Parameter	Symbol	Min	Max	Unit
RF input power (CW mode)	$EP_{in}$	-	+28	dBm
Optical input power (CW mode)	$OP_{in}$	-	+14	dBm
Operating temperature	OT	0	+70	°C
Storage temperature	ST	-40	+85	°C

# MODULATOR | NIR-MPX800-LN SERIES | 6/6

## Mechanical Diagram and Pinout

All measurements in mm

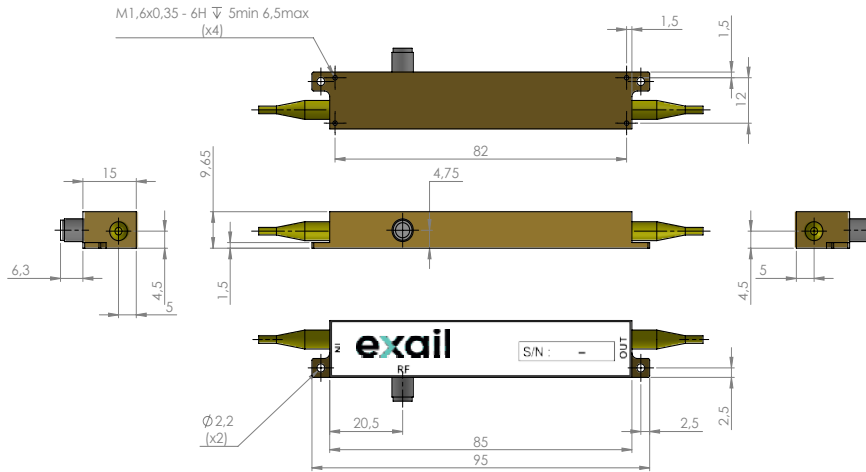

Port	Function	Note
IN	Optical input port	Polarization maintaining 800 nm Corning PM 85-U25D Length: 1.5 meter, buffer diameter: 900 µm
OUT	Optical output port	Polarization maintaining 800 nm Corning PM 85-U25D Length: 1.5 meter, buffer diameter: 900 µm
RF	RF input port	Female K

## Ordering information

Bandwidth: **0.1** (150 MHz), **05** (5 GHz), **10** (10 GHz), **20** (20 GHz)

Input fiber: **P** (Polarisation maintaining)

Output fiber: **P** (Polarisation maintaining)

Input connector: **00** (bare fiber), FA (FC/APC)

Output connector: **00** (bare fiber), FA (FC/APC)

NIR-MPX800-LN - □ - 00 - □ - □ - □ - □

## About us

Exail reserves the right to change, at any time and without notice, the specifications, design, function or form of its products described herein.

contact.photonics@exail.com | www.exail.com

Europe +33 1 30 08 87 43 | Americas +1 508 745 3487 | APAC +65 6747 4912

